

# DATA SHEET

**BFR505**

**NPN 9 GHz wideband transistor**

Product specification  
File under Discrete Semiconductors, SC14

September 1995

## NPN 9 GHz wideband transistor

## BFR505

## FEATURES

- High power gain
- Low noise figure
- High transition frequency
- Gold metallization ensures excellent reliability.

## PINNING

| PIN       | DESCRIPTION |
|-----------|-------------|
| Code: N30 |             |
| 1         | base        |
| 2         | emitter     |
| 3         | collector   |

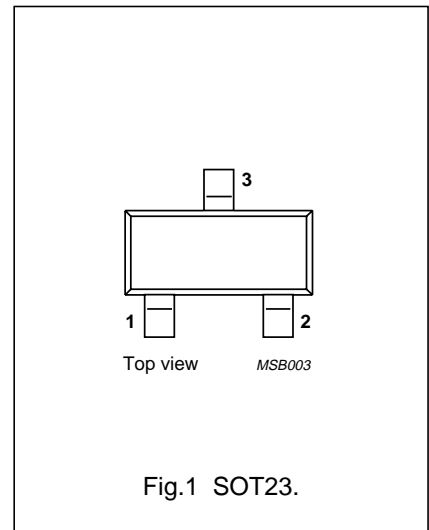

## DESCRIPTION

The BFR505 is an npn silicon planar epitaxial transistor, intended for applications in the RF frontend in wideband applications in the GHz range, such as analog and digital cellular telephones, cordless telephones (CT1, CT2, DECT, etc.), radar detectors, pagers and satellite TV tuners (SATV).

The transistor is encapsulated in a plastic SOT23 envelope.

## QUICK REFERENCE DATA

| SYMBOL       | PARAMETER                     | CONDITIONS  | MIN. | TYP. | MAX. | UNIT |
|--------------|-------------------------------|---|------|------|------|------|
| $V_{CB0}$    | collector-base voltage        | open emitter  | –    | –    | 20   | V    |
| $V_{CES}$    | collector-emitter voltage     | $R_{BE} = 0$  | –    | –    | 15   | V    |
| $I_C$        | DC collector current          |   | –    | –    | 18   | mA   |
| $P_{tot}$    | total power dissipation       | up to $T_s = 135\text{ °C}$ ; note 1  | –    | –    | 150  | mW   |
| $h_{FE}$     | DC current gain               | $I_C = 5\text{ mA}$ ; $V_{CE} = 6\text{ V}$   | 60   | 120  | 250  |      |
| $C_{re}$     | feedback capacitance          | $I_C = i_c = 0$ ; $V_{CB} = 6\text{ V}$ ; $f = 1\text{ MHz}$  | –    | 0.3  | –    | pF   |
| $f_T$        | transition frequency          | $I_C = 5\text{ mA}$ ; $V_{CE} = 6\text{ V}$ ; $f = 1\text{ GHz}$  | –    | 9    | –    | GHz  |
| $G_{UM}$     | maximum unilateral power gain | $I_C = 5\text{ mA}$ ; $V_{CE} = 6\text{ V}$ ;<br>$T_{amb} = 25\text{ °C}$ ; $f = 900\text{ MHz}$                                | –    | 17   | –    | dB   |
|              |                               | $I_C = 5\text{ mA}$ ; $V_{CE} = 6\text{ V}$ ;<br>$T_{amb} = 25\text{ °C}$ ; $f = 2\text{ GHz}$                                  | –    | 10   | –    | dB   |
| $ S_{21} ^2$ | insertion power gain          | $I_C = 5\text{ mA}$ ; $V_{CE} = 6\text{ V}$ ;<br>$T_{amb} = 25\text{ °C}$ ; $f = 900\text{ MHz}$                                | 13   | 14   | –    | dB   |
| F            | noise figure                  | $\Gamma_s = \Gamma_{opt}$ ; $I_C = 1.25\text{ mA}$ ; $V_{CE} = 6\text{ V}$ ;<br>$T_{amb} = 25\text{ °C}$ ; $f = 900\text{ MHz}$ | –    | 1.2  | 1.7  | dB   |
|              |                               | $\Gamma_s = \Gamma_{opt}$ ; $I_C = 5\text{ mA}$ ; $V_{CE} = 6\text{ V}$ ;<br>$T_{amb} = 25\text{ °C}$ ; $f = 900\text{ MHz}$    | –    | 1.6  | 2.1  | dB   |
|              |                               | $\Gamma_s = \Gamma_{opt}$ ; $I_C = 1.25\text{ mA}$ ; $V_{CE} = 6\text{ V}$ ;<br>$T_{amb} = 25\text{ °C}$ ; $f = 2\text{ GHz}$   | –    | 1.9  | –    | dB   |

## Note

1.  $T_s$  is the temperature at the soldering point of the collector tab.

## NPN 9 GHz wideband transistor

BFR505

**LIMITING VALUES**

In accordance with the Absolute Maximum System (IEC 134).

| SYMBOL    | PARAMETER                 | CONDITIONS                           | MIN. | MAX. | UNIT |
|-----------|---------------------------|--------------------------------------|------|------|------|
| $V_{CBO}$ | collector-base voltage    | open emitter                         | –    | 20   | V    |
| $V_{CES}$ | collector-emitter voltage | $R_{BE} = 0$                         | –    | 15   | V    |
| $V_{EBO}$ | emitter-base voltage      |                                      | –    | 2.5  | V    |
| $I_C$     | DC collector current      | continuous                           | –    | 18   | mA   |
| $P_{tot}$ | total power dissipation   | up to $T_s = 135\text{ °C}$ ; note 1 | –    | 150  | mW   |
| $T_{stg}$ | storage temperature       |                                      | –65  | 150  | °C   |
| $T_j$     | junction temperature      |                                      | –    | 175  | °C   |

**THERMAL RESISTANCE**

| SYMBOL        | PARAMETER                                 | THERMAL RESISTANCE |
|---------------|---|--------------------|
| $R_{th\ j-s}$ | from junction to soldering point (note 1) | 260 K/W            |

**Note**

- $T_s$  is the temperature at the soldering point of the collector tab.

## NPN 9 GHz wideband transistor

## BFR505

## CHARACTERISTICS

$T_j = 25\text{ °C}$  unless otherwise specified.

| SYMBOL       | PARAMETER                              | CONDITIONS   | MIN. | TYP. | MAX. | UNIT |
|--------------|--|--|------|------|------|------|
| $I_{CBO}$    | collector cut-off current              | $I_E = 0; V_{CB} = 6\text{ V}$   | –    | –    | 50   | nA   |
| $h_{FE}$     | DC current gain                        | $I_C = 5\text{ mA}; V_{CE} = 6\text{ V}$   | 60   | 120  | 250  |      |
| $C_e$        | emitter capacitance                    | $I_C = i_c = 0; V_{EB} = 0.5\text{ V}; f = 1\text{ MHz}$   | –    | 0.4  | –    | pF   |
| $C_c$        | collector capacitance                  | $I_E = i_e = 0; V_{CB} = 6\text{ V}; f = 1\text{ MHz}$   | –    | 0.4  | –    | pF   |
| $C_{re}$     | feedback capacitance                   | $I_C = 0; V_{CB} = 6\text{ V}; f = 1\text{ MHz}$   | –    | 0.3  | –    | pF   |
| $f_T$        | transition frequency                   | $I_C = 5\text{ mA}; V_{CE} = 6\text{ V}; f = 1\text{ GHz}$   | –    | 9    | –    | GHz  |
| $G_{UM}$     | maximum unilateral power gain (note 1) | $I_C = 5\text{ mA}; V_{CE} = 6\text{ V};$<br>$T_{amb} = 25\text{ °C}; f = 900\text{ MHz}$                          | –    | 17   | –    | dB   |
|              |  | $I_C = 5\text{ mA}; V_{CE} = 6\text{ V};$<br>$T_{amb} = 25\text{ °C}; f = 2\text{ GHz}$                            | –    | 10   | –    | dB   |
| $ S_{21} ^2$ | insertion power gain                   | $I_C = 5\text{ mA}; V_{CE} = 6\text{ V};$<br>$T_{amb} = 25\text{ °C}; f = 900\text{ MHz}$                          | 13   | 14   | –    | dB   |
| F            | noise figure                           | $\Gamma_s = \Gamma_{opt}; I_C = 5\text{ mA}; V_{CE} = 6\text{ V};$<br>$T_{amb} = 25\text{ °C}; f = 900\text{ MHz}$ | –    | 1.2  | 1.7  | dB   |
|              |  | $\Gamma_s = \Gamma_{opt}; I_C = 5\text{ mA}; V_{CE} = 6\text{ V};$<br>$T_{amb} = 25\text{ °C}; f = 900\text{ MHz}$ | –    | 1.6  | 2.1  | dB   |
|              |  | $\Gamma_s = \Gamma_{opt}; I_C = 5\text{ mA}; V_{CE} = 6\text{ V};$<br>$T_{amb} = 25\text{ °C}; f = 2\text{ GHz}$   | –    | 1.9  | –    | dB   |
| $P_{L1}$     | output power at 1 dB gain compression  | $I_C = 5\text{ mA}; V_{CE} = 6\text{ V}; R_L = 50\ \Omega;$<br>$T_{amb} = 25\text{ °C}; f = 900\text{ MHz}$        | –    | 4    | –    | dBm  |
| ITO          | third order intercept point            | note 2   | –    | 10   | –    | dBm  |

## Notes

1.  $G_{UM}$  is the maximum unilateral power gain, assuming  $S_{12}$  is zero and

$$G_{UM} = 10 \log \left( \frac{|S_{21}|^2}{(1 - |S_{11}|^2)(1 - |S_{22}|^2)} \right) \text{ dB.}$$

2.  $I_C = 5\text{ mA}; V_{CE} = 6\text{ V}; R_L = 50\ \Omega; T_{amb} = 25\text{ °C};$   
 $f_p = 900\text{ MHz}; f_q = 902\text{ MHz};$   
 measured at  $f_{(2p-q)} = 898\text{ MHz}$  and  $f_{(2q-p)} = 904\text{ MHz}.$

NPN 9 GHz wideband transistor

BFR505

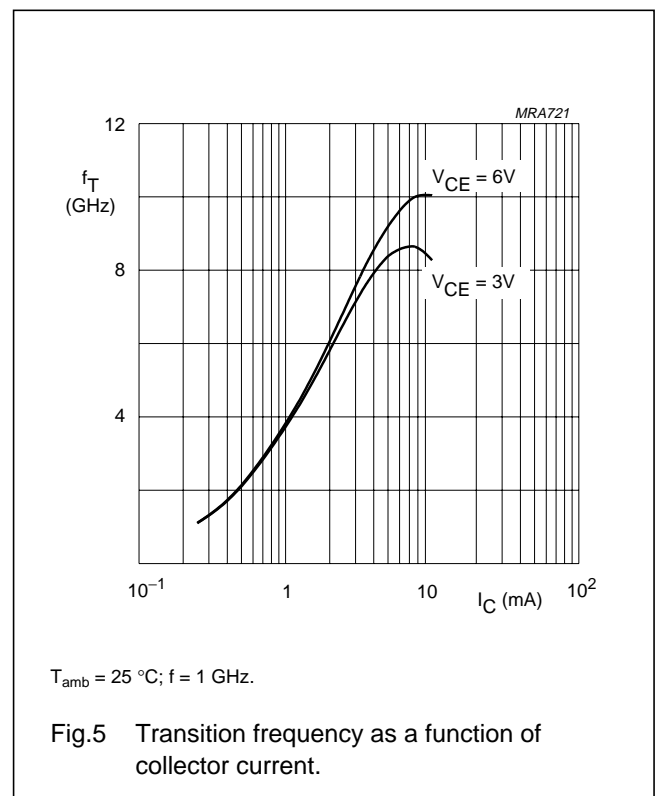
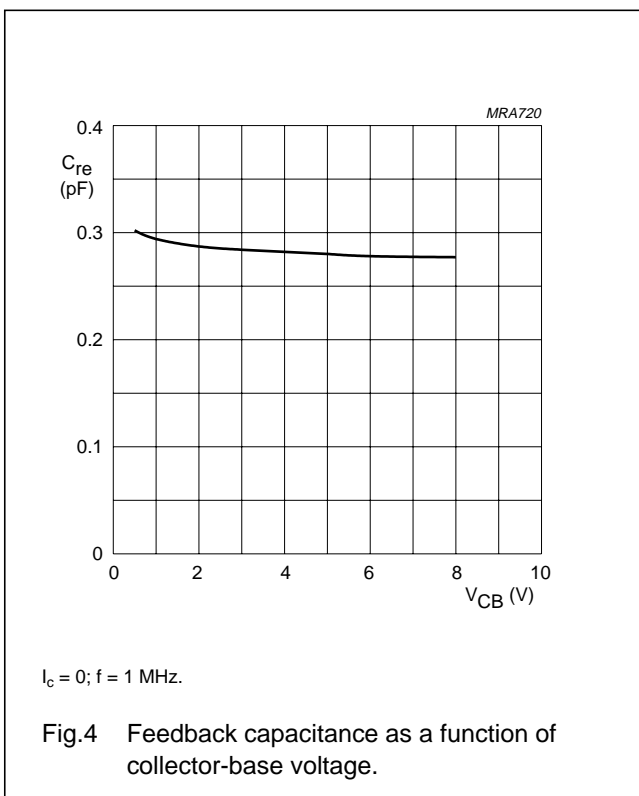
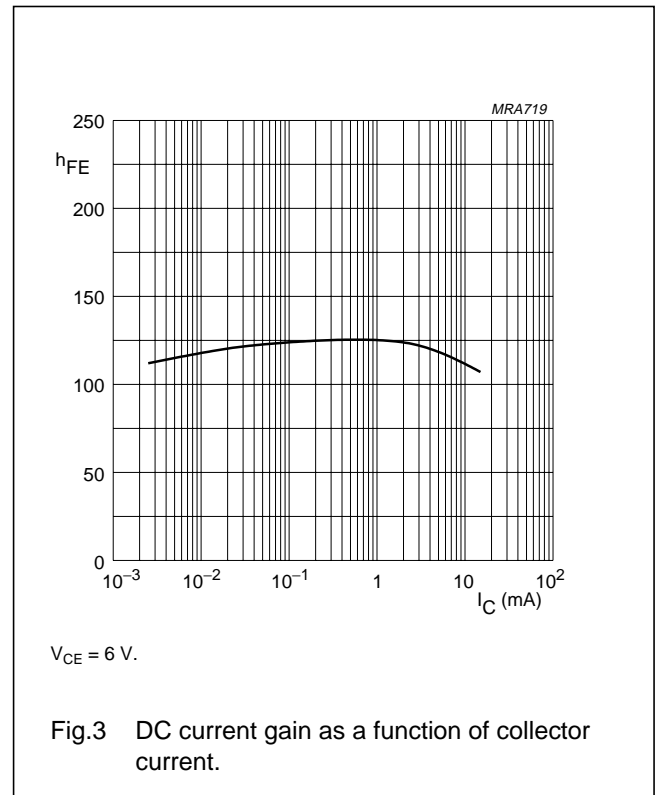
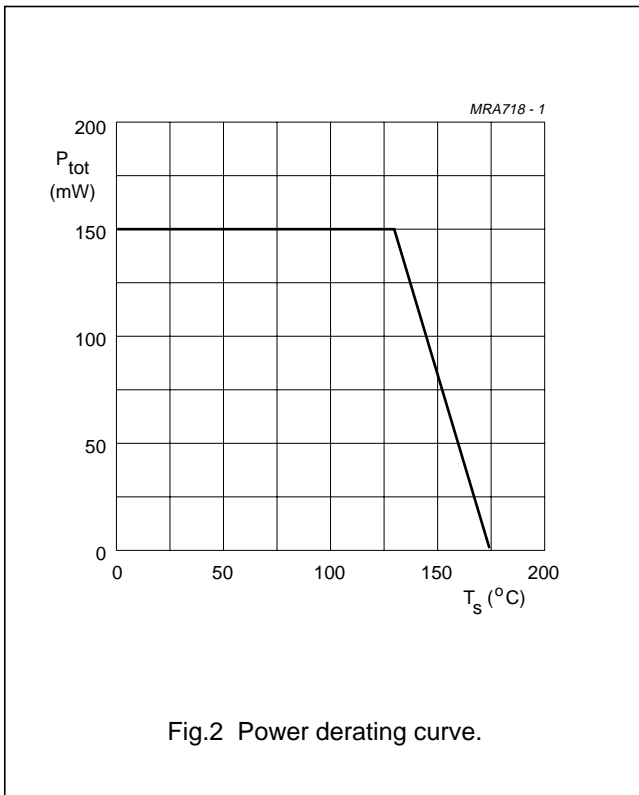

NPN 9 GHz wideband transistor

BFR505

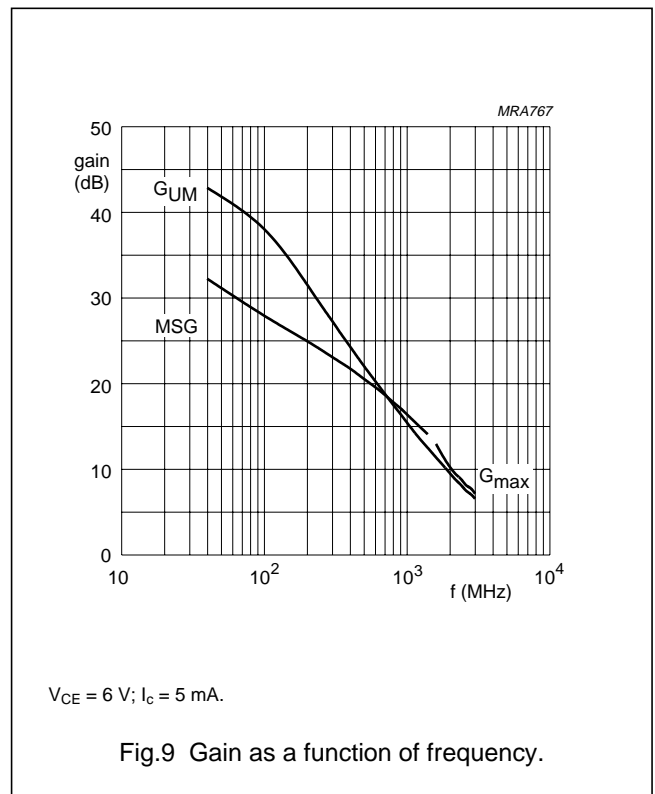
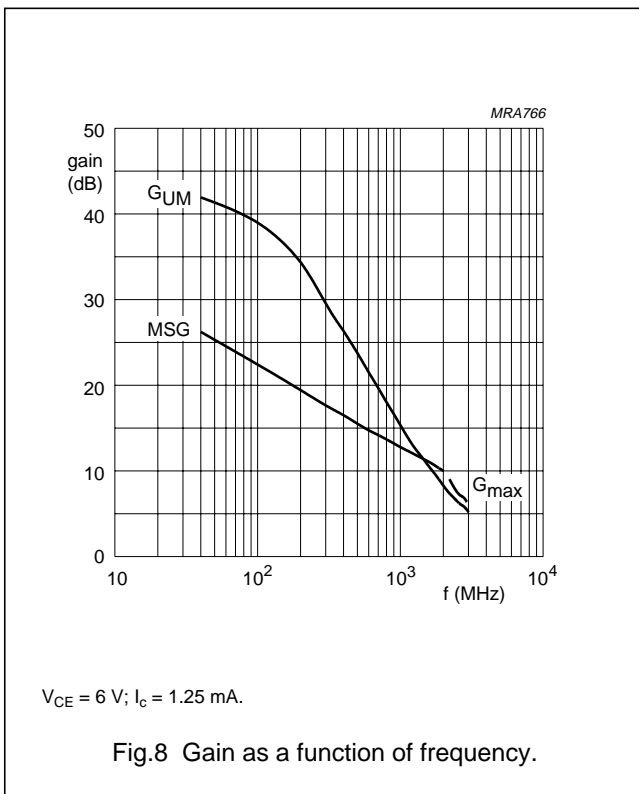
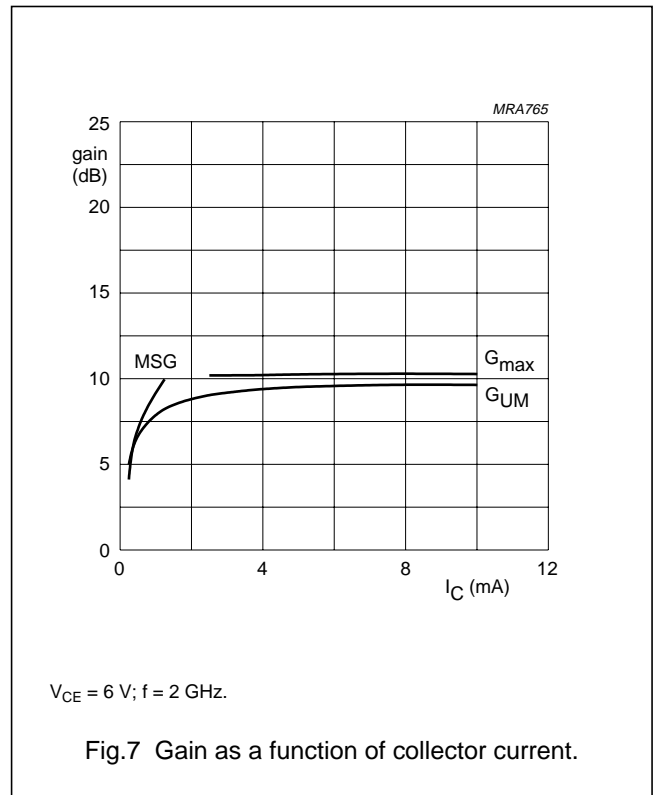
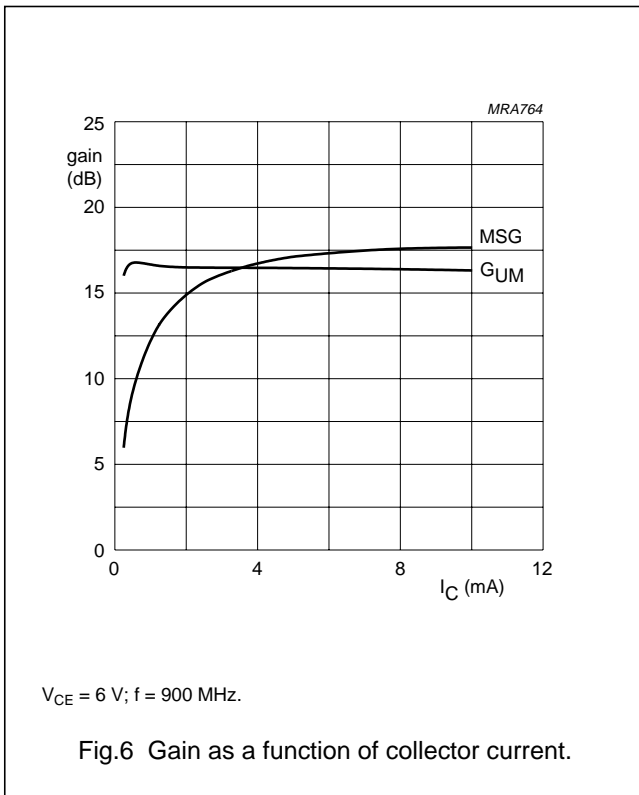

NPN 9 GHz wideband transistor

BFR505

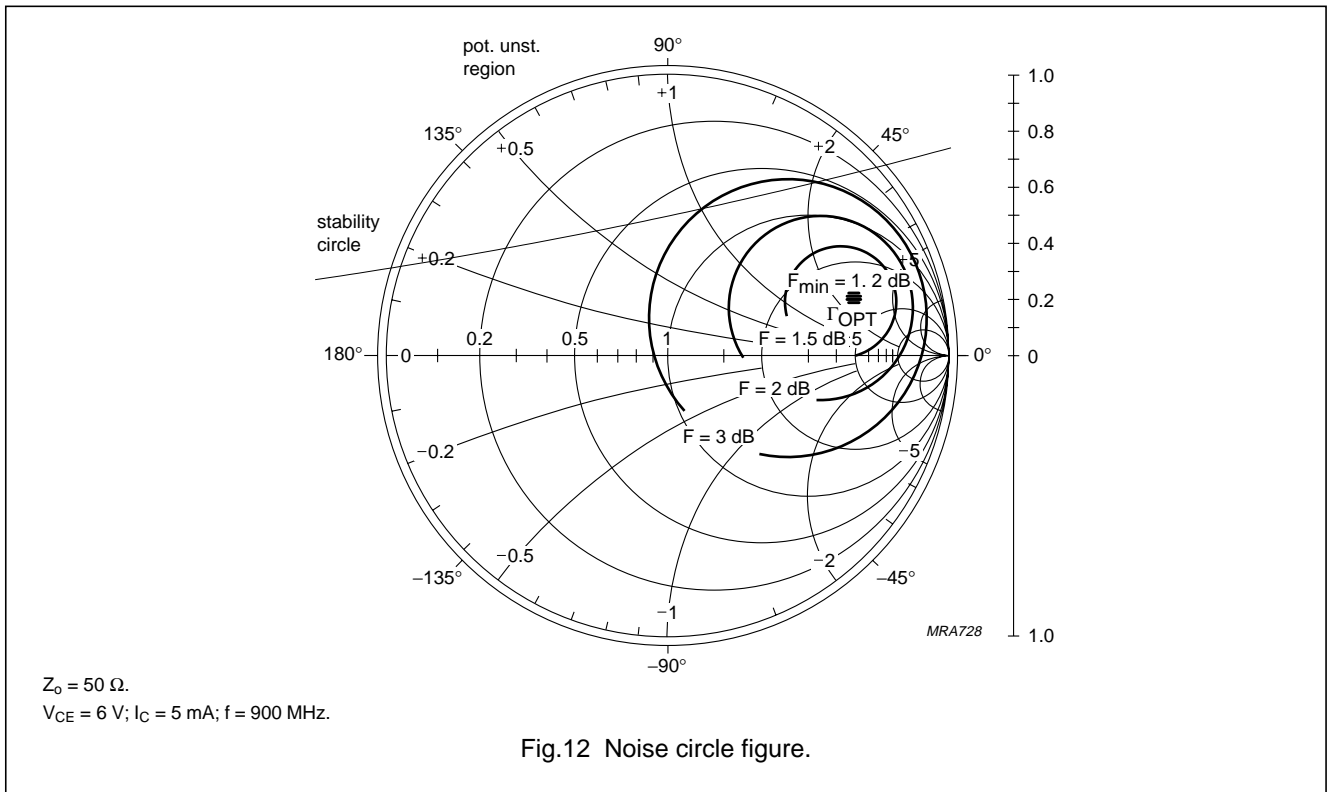
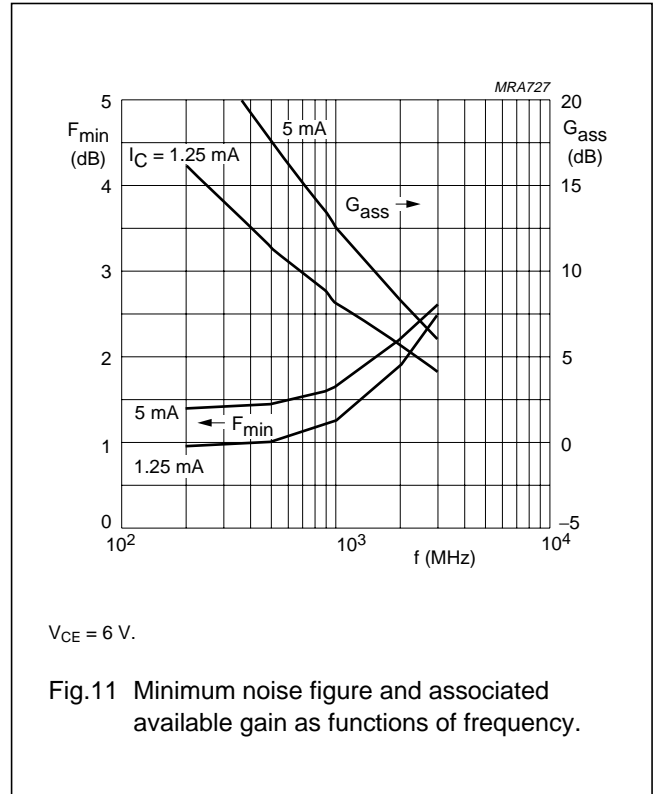
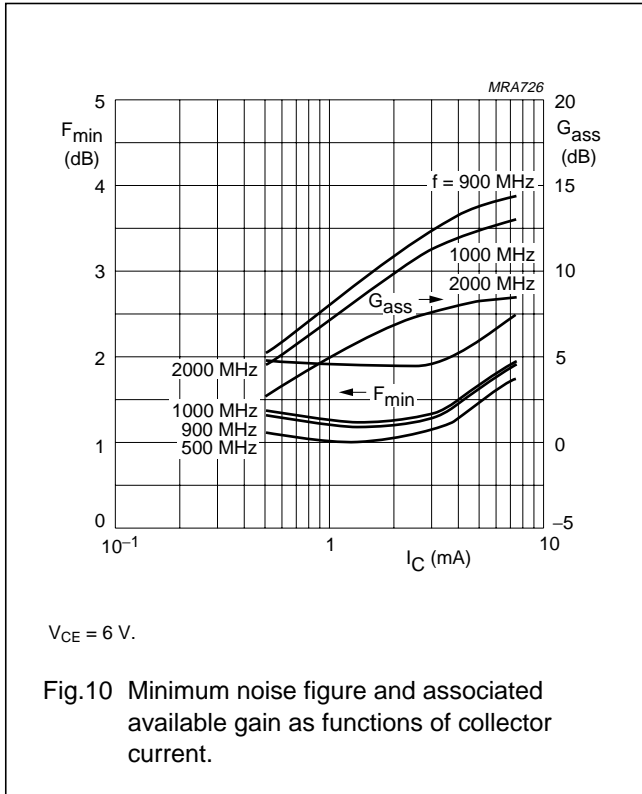

NPN 9 GHz wideband transistor

BFR505

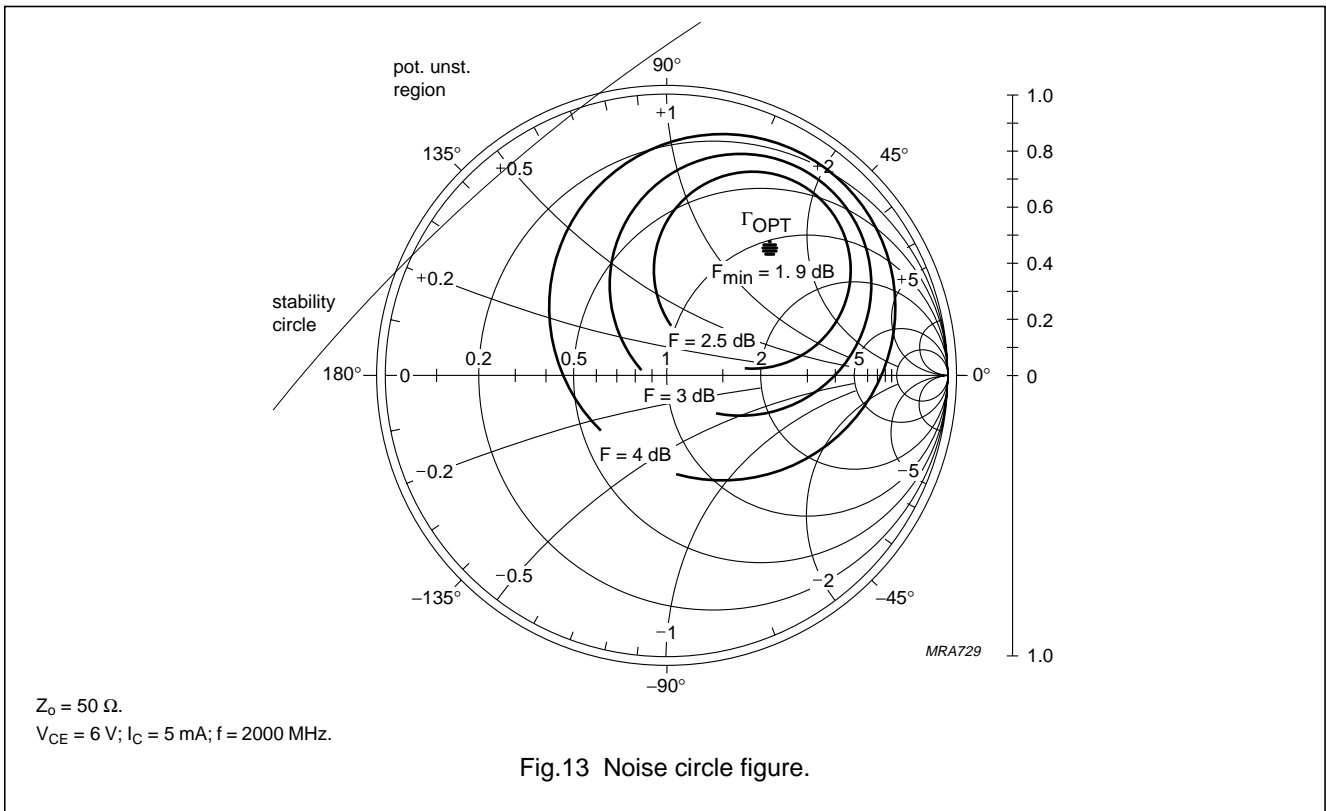

NPN 9 GHz wideband transistor

BFR505

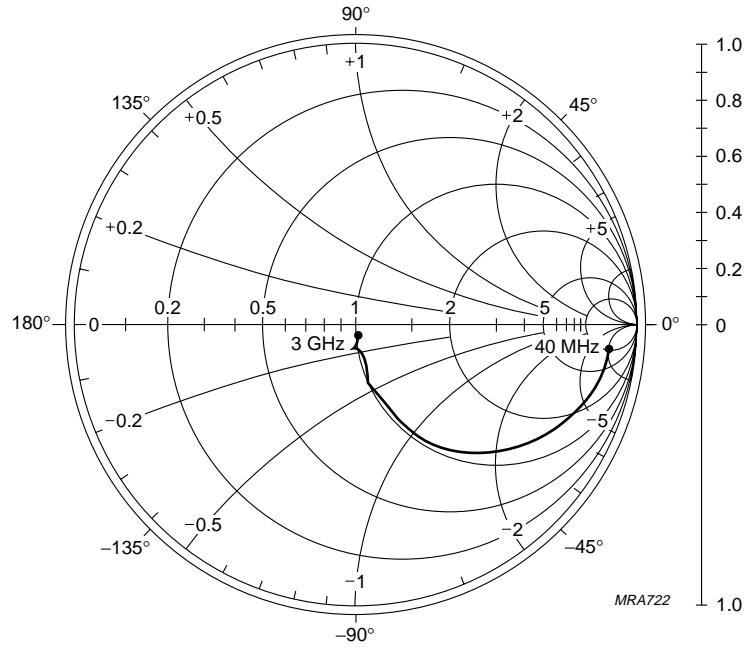

$V_{CE} = 6\text{ V}; I_C = 5\text{ mA}.$   
 $Z_0 = 50\ \Omega.$

Fig.14 Common emitter input reflection coefficient ( $S_{11}$ ).

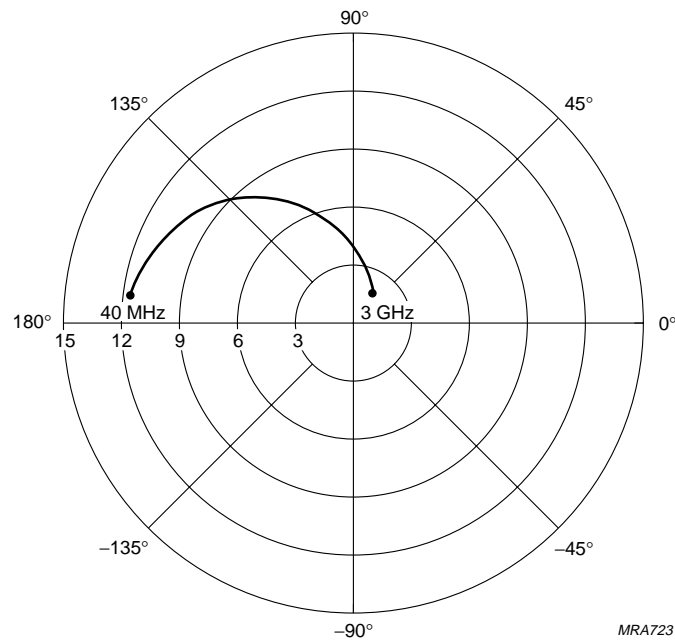

$V_{CE} = 6\text{ V}; I_C = 5\text{ mA}.$

Fig.15 Common emitter forward transmission coefficient ( $S_{21}$ ).

NPN 9 GHz wideband transistor

BFR505

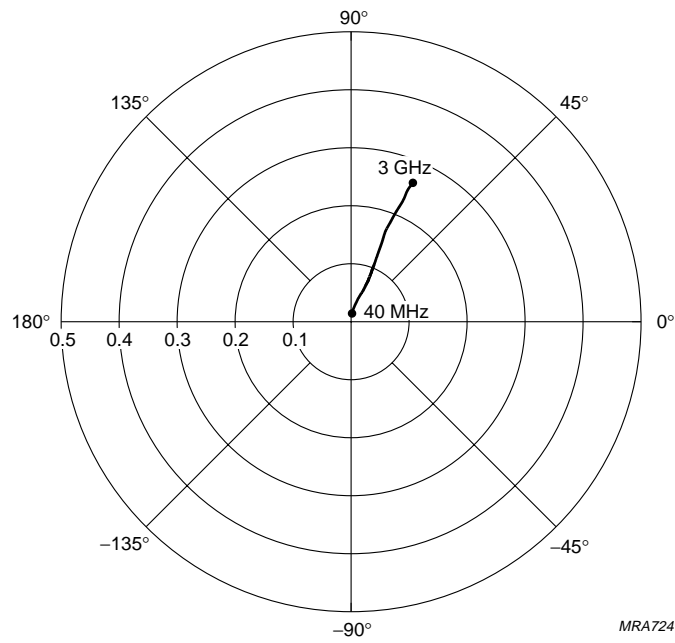

MRA724

$V_{CE} = 6\text{ V}; I_C = 5\text{ mA}.$

Fig.16 Common emitter reverse transmission coefficient ( $S_{12}$ ).

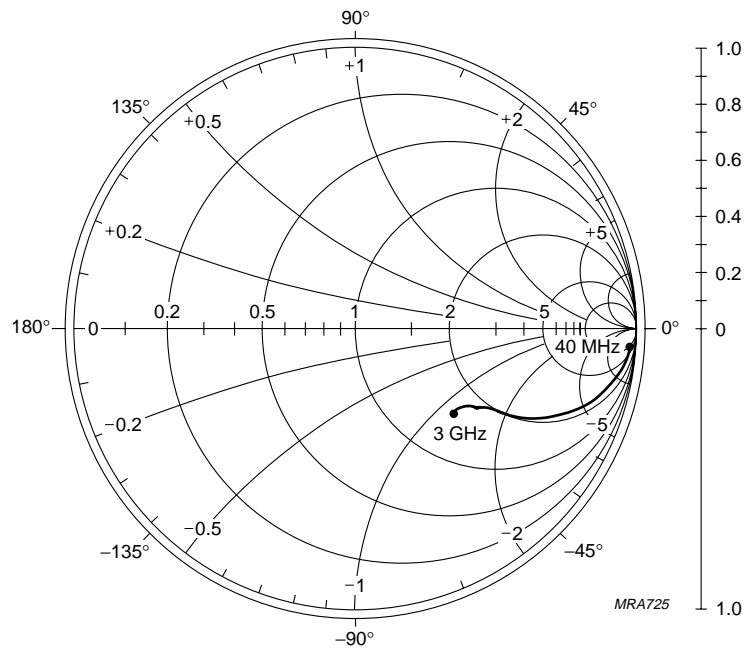

MRA725

$V_{CE} = 6\text{ V}; I_C = 5\text{ mA}.$   
 $Z_0 = 50\ \Omega.$

Fig.17 Common emitter output reflection coefficient ( $S_{22}$ ).

NPN 9 GHz wideband transistor

BFR505

PACKAGE OUTLINE

Plastic surface mounted package; 3 leads

SOT23

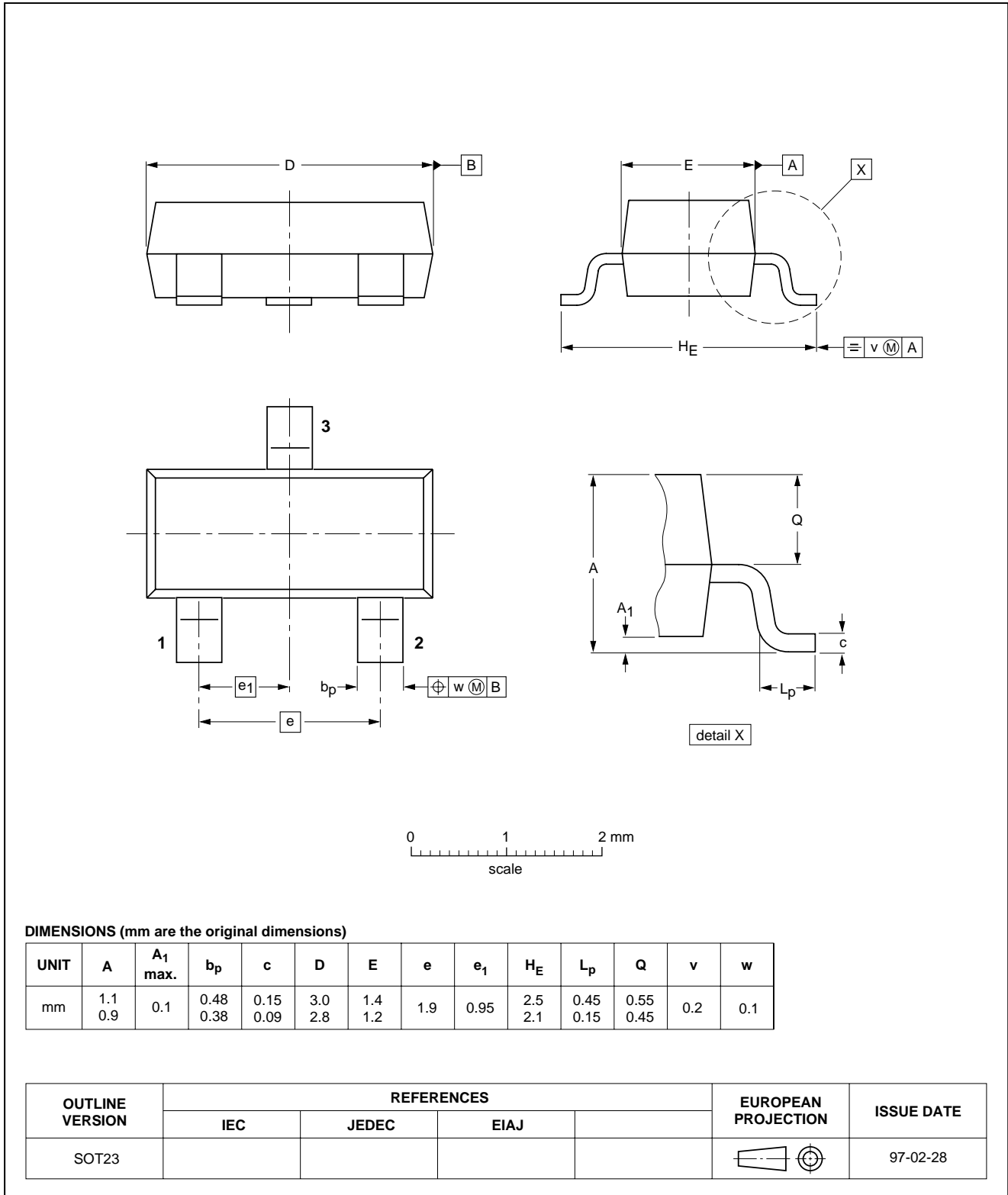

## NPN 9 GHz wideband transistor

BFR505

**DEFINITIONS**

| <b>Data Sheet Status</b>  |   |
|---|---|
| Objective specification   | This data sheet contains target or goal specifications for product development.       |
| Preliminary specification   | This data sheet contains preliminary data; supplementary data may be published later. |
| Product specification   | This data sheet contains final product specifications.                                |
| <b>Limiting values</b>  |   |
| Limiting values given are in accordance with the Absolute Maximum Rating System (IEC 134). Stress above one or more of the limiting values may cause permanent damage to the device. These are stress ratings only and operation of the device at these or at any other conditions above those given in the Characteristics sections of the specification is not implied. Exposure to limiting values for extended periods may affect device reliability. |   |
| <b>Application information</b>  |   |
| Where application information is given, it is advisory and does not form part of the specification.   |   |

**LIFE SUPPORT APPLICATIONS**

These products are not designed for use in life support appliances, devices, or systems where malfunction of these products can reasonably be expected to result in personal injury. Philips customers using or selling these products for use in such applications do so at their own risk and agree to fully indemnify Philips for any damages resulting from such improper use or sale.